

# Scooter and Wheelchair Travel Pass

Information and application form  
Effective October 2019

## Am I eligible?

You may be eligible for a Scooter and Wheelchair Travel Pass if you;

- depend on a scooter/wheelchair for mobility outside the home
- have a permanent condition (i.e not expected to improve with time or surgery)
- are a permanent Victorian resident

You may also be eligible for:

- Multi-Purpose Taxi Program – [taxi.vic.gov.au/passengers/mptp](http://taxi.vic.gov.au/passengers/mptp)

## How does it work?

The Scooter and Wheelchair Travel Pass is a registered myki card that includes your name and photo.

The Scooter and Wheelchair Travel Pass gives you free travel on:

- trains, trams and buses in metropolitan Melbourne
- V/Line train and coach services
- regional town bus services
- other services operated by Public Transport Victoria.

Customers should check if their free travel pass is accepted before travelling with an interstate or private operator. These include NSW TrainLink, Great Southern Railway, airport services, tourist railways, privately run bus services and chartered trains, trams and buses.

Carry your pass with you when travelling. You don't need to touch on or off, but you'll need to show it to station staff to go through station gates and may be asked to show it to public transport staff.

The Scooter and Wheelchair Travel Pass is free.

## How do I apply?

1. Complete this application form
2. Attach one colour passport size photo which has been verified – Section 2
3. Have your health professional complete Section 4
4. Send the form (flat and unfolded) to:

### **Scooter and Wheelchair Travel Pass Applications**

PTV Hub  
PO Box 4724  
Melbourne VIC 3001

Or deliver in person to:

PTV Hub  
Southern Cross Station

**Please note:** We can't process an incomplete form or return forms and photos. Photocopied applications are not accepted.

If you qualify for the Scooter and Wheelchair Travel Pass, you will be notified by mail within 10 business days.

# Section 1: Applicant

## 1.1 Applicant's details

Title (Mr, Mrs, Miss, Ms, other)

Surname

First Name

Date of Birth (dd/mm/yyyy)

Address

Unit number

Street number

Street name

Suburb/town

State

Postcode

Postal Address (If different from above)

Unit number

Street number

PO Box number

Street name

Suburb/town

State

Postcode

Daytime phone number (with area code)

Email

**1.2 Are you a permanent Victorian resident?**

- Yes
- No – Unfortunately you are not eligible

**1.3 Have you previously applied for the Scooter and Wheelchair Travel Pass?**

- Yes
- No

**1.4 Do you have a Multi-Purpose Taxi Program (MPTP) card that certifies you depend on a **wheelchair** for mobility outside the home?**

- Yes – write your MPTP number in the boxes below.  
**You don't need to complete Section 4.**

|  |  |  |  |  |  |  |  |  |  |  |  |  |  |  |  |  |  |  |  |  |
|--|--|--|--|--|--|--|--|--|--|--|--|--|--|--|--|--|--|--|--|--|
|  |  |  |  |  |  |  |  |  |  |  |  |  |  |  |  |  |  |  |  |  |
|--|--|--|--|--|--|--|--|--|--|--|--|--|--|--|--|--|--|--|--|--|

- No – You must complete section 4

**Office use only**

MPTP card classified for wheelchair use

- Yes
- No

MPTP staff member verification \_\_\_\_\_

Name of PTV employee \_\_\_\_\_

Signature of PTV employee

## Section 2: Photo

**2.1** Attach one recent (no more than three months old) colour, passport size photo using a paper clip only.

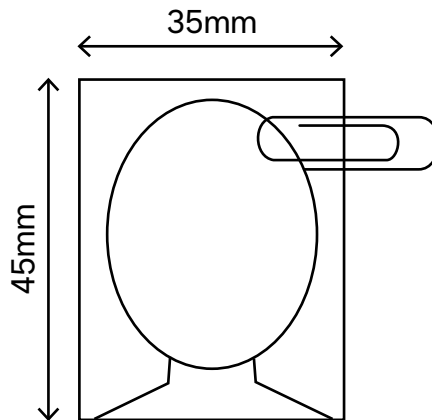
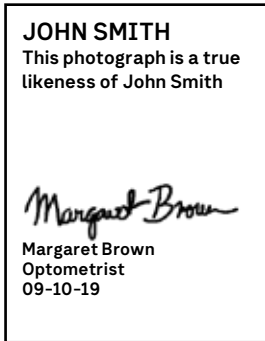

## 2.2 Verify your identity

**Submitting by post** Ask your health care professional or Justice of the Peace to print your full name on the back of your photo and sign it, certifying it is a true likeness of you. See the example above.

**Submitting in person** Your passport photo can be verified by a PTV Hub employee. You will also need to bring formal photo ID to verify your identity.

Your photo is kept on file to make it easier to send you a replacement pass, if needed.

### Section 3: Applicant or legal guardian/agent declaration

I, \_\_\_\_\_  
(name of applicant) declare that all information provided and the following is true and accurate, that I:

- live with a permanent and severe disability (being for the term of my life and not expected to improve) and depend on a scooter or wheelchair for mobility outside my home
- authorise public transport authorities to verify the information in this form and to obtain and disclose any information relating to this application for the purpose of assessing the applicant's eligibility for a Scooter and Wheelchair Travel Pass
- agree that the health professional who completes Section 4 may share information about me to help assess the application
- am a permanent Victorian resident
- have read and acknowledge the Disability Standards for Accessible Public Transport 2002 (Section 5)
- have read or had explained to me and accept the terms and conditions (Section 6)
- have read or had explained to me and accept the privacy collection notice (Section 7).

Signature

Date (dd/mm/yyyy)

|   |   |   |   |   |   |   |   |
|---|---|---|---|---|---|---|---|
| D | D | M | M | Y | Y | Y | Y |
|---|---|---|---|---|---|---|---|

Signature of applicant/guardian/agent (must be 16 years and over)

#### If signed by a guardian/agent, please complete the following;

If the applicant is under 16 years of age or is unable to sign the application, the applicant's guardian/agent needs to complete and sign the section below.

I, \_\_\_\_\_  
(name of guardian/agent) declare that I have read and explained the contents of this application to the applicant and that the details set out for the applicant are correct.

Relationship to applicant

Phone number (with area code)

## Section 4: Health practitioner declaration

### 4.1 I am a practicing:

- General Practitioner
- Specialist (please specify)

### 4.2 Does the applicant permanently (being for the term of their life and not expected to improve) depend on a scooter or wheelchair for mobility outside their home, due to their disability?

- Yes
- No

### 4.3 Describe the nature of the applicant's condition and why they depend on a scooter or wheelchair for mobility outside the home.





## **Section 5 – Disability Standards for Accessible Public Transport 2002 – scooter and wheelchair size**

These standards set out the specifications for public transport in its capacity to accommodate scooters and wheelchairs. If your application is approved and your mobility aid can't meet these standards, there's no guarantee you'll be able to access all forms of public transport.

### **Dimensions**

Your scooter or wheelchair needs to:

- fit within an allocated space of 1300mm by 800mm
- be no more than 750mm wide, 300mm high above ground
- weigh no more than 300kg when combined with you and an assistant.

These specifications will allow you and your mobility aid to fit between the wheel axles of a bus and be lifted by a boarding device when needed (e.g. ramp) which has a maximum capacity of 300kg.

### **Stability**

Your mobility aid needs to:

- be able to move in the direction determined by the transport operator
- have effective braking systems to maintain stability.

### **Manoeuvrability**

Your scooter or wheelchair should be able to:

- turn 180 degrees in an area 2070mm by 1540mm
- cross a horizontal gap of up to 40mm wide
- mount a vertical rise (i.e. bump) of up to 12mm
- cross grating gaps up to 13mm wide and 150mm long
- negotiate up to a 1:8 grade where the ramp is less than 1520mm
- negotiate a 1:4 grade with assistance (e.g. ramp).

## Section 6 – Terms and conditions

1. This pass is only valid for the person whose photo and name appears on it.
2. You need to carry your pass when travelling on public transport in Victoria.
3. Show your pass to a public transport employee, when requested.
4. Your pass remains the property of PTV. If you tamper with your pass, it may be cancelled.
5. If you lose your pass or it's ever stolen, damaged or becomes inactive, you'll let us know as soon as possible by calling (03) 9619 2710. We'll send you a free replacement pass.
6. Your myki is issued subject to, and its use is governed by, the myki Terms of Use, the Transport (Compliance and Miscellaneous) Act (1983) and related regulations, and the Victorian Fares and Ticketing Manual (myki) ('Ticket Conditions'), as amended from time to time. The myki Terms of Use limit Public Transport Victoria's PTV liability and may impose certain fees.

## Section 7 – Privacy collection notice

Your personal information, provided by you and generated by the card, is collected by public transport authorities to issue and administer the card.

If you don't provide the information required, we may not be able to provide you with a free myki.

Your personal information may be used or shared amongst public transport authorities for the operation of myki, to verify entitlement to a free travel pass, for ticketing enforcement, in emergencies, as required or authorised under law, with your consent. You'll be able to access your personal information.

Public Transport Victoria (PTV) understands and respects your right to privacy and is committed to privacy protection. The Privacy and Data Protection Act 2014 and PTV's Privacy Policy regulate how we collect and handle your personal information. For more information on terms and conditions and privacy, visit [ptv.vic.gov.au](http://ptv.vic.gov.au) or contact PTV's Information Privacy Officer by phone **1800 800 007** or email [ptvprivacy@ptv.vic.gov.au](mailto:ptvprivacy@ptv.vic.gov.au)

For more information visit [ptv.vic.gov.au](http://ptv.vic.gov.au) or call **1800 800 007**.

If you're deaf, or have a hearing or speech impairment, contact us through the National Relay Service – for more information, visit [relayservice.gov.au](http://relayservice.gov.au)



For information in other languages:

|                 |           |                |           |
|-----------------|-----------|----------------|-----------|
| 普通話             | 9321 5454 | 廣東話            | 9321 5441 |
| <b>Italiano</b> | 9321 5444 | ਪੰਜਾਬੀ         | 9321 5445 |
| <b>Ελληνικά</b> | 9321 5443 | हिन्दी         | 9321 5442 |
| <b>Việt-ngữ</b> | 9321 5449 | සිංහල          | 9321 5446 |
| عربي            | 9321 5440 | <b>Español</b> | 9321 5447 |

If your language isn't listed visit [ptv.vic.gov.au/languages](http://ptv.vic.gov.au/languages) or call **9321 5450**.